



# Pieceful Times

November 2009

Meeting  
MONDAY, NOV 2<sup>nd</sup>  
7:30 PM  
(Doors open at 7 PM  
for refreshments & social time )  
St. Anthony's  
Soccer Club  
St. Anthony Street  
(west side of Preston St.  
directly north of the  
Queensway/ 417)



Remember to bring your

- membership card
- name tag
- mug
- small change

**Guests welcome!**  
(\$5 admission)  
Next Meeting  
MONDAY, DEC 7<sup>th</sup>

## Inside this issue

2009/10 Committees	2
Program	2
Bookmarks	3
At Home with Quilts	3
Library	3
Membership	3
Charity Activities	4
Baby Quilts	5
Mystery Quilt	6
Workshops	8
Block of the Month	12
New Zealand Visitors	13
Coming Events	15

## PIECEFUL PONDERINGS FROM THE PREZ,

Some of you know that I run marathons and that I took up quilting when I was injured. Now I do both. As you read this I will be in Ireland running the Dublin marathon and then seeing the sights. I have found that marathon running and quilting do have some similarities:

- You can't just go run a marathon or complete a quilt – it does take some training;
- If you fall behind in your training (or piecing) it is difficult to catch up;
- You get out what you put into it;
- There are times when you feel like you will never finish;
- There are times you want to throw in the towel;
- If you persist you will be successful;
- The goal is the journey not the destination;
- Stretching is helpful for both activities;
- You meet great people along the way;
- AND ....It's a good excuse to travel

We're scheduled to arrive back in Ottawa just four hours before the November 2<sup>nd</sup> Guild meeting. I apologize in advance if I'm a bit blurry-eyed!

Happy Quilting,  
Jann

## NOVEMBER SHOP OF THE MONTH ...

### KITAMBAA DESIGNS.

Pippa Moore, this month's program guest, is bringing a selection of her unique African fabrics. See samples on her website at [www.pippamoore.ca/](http://www.pippamoore.ca/) fabrics.

Ottawa Valley Quilters' Guild

1430 Prince of Wales Dr., PO Box 38083 Ottawa ON K2C 1N0

Information about Guild policies, programs, etc. can be found in our Members' Handbook available from the Membership Committee or on our website [www.ottawavalleyquiltersguild.org](http://www.ottawavalleyquiltersguild.org)

## GUILD EXECUTIVE

**President:** Jann Thulien  
president@OttawaValleyQuiltersGuild.org

**V.P. Programs:** Pat Amundrud  
vpprogram@OttawaValleyQuiltersGuild.org

**V.P. Administration:** Trudy Seliger  
vpadmin@OttawaValleyQuiltersGuild.org

**Secretary:** Carol Kerfoot, also Marie Fleming

**Co-Treasurers:** Adeline Alkan, Deborah Bouck

**Past Co-Presidents:** Eden Thurston,  
Michèle-Renée Charbonneau

**Archives:** Donna Nesbitt, Barb Cloutier

**Baby Quilts:** Carole Carraro  
babyquilts@OttawaValleyQuiltersGuild.org

**Block of the Month:** Robin Tilsworth, Heather Jarmyn

**Charity /Raffle Quilts:** Jane Roszell  
charity@OttawaValleyQuiltersGuild.org

**Equipment:** Angèle Vanderlaan

**Library:** Dorothy Wilson, Linda Hill  
library@OttawaValleyQuiltersGuild.org

**Magazines:** Jutta Hof, Joyce Bruno

**Membership:** Carol Baker, Janet Major,  
Christine deVries, Judy Smith  
membership@OttawaValleyQuiltersGuild.org

**Newsletter:** Linda Doyle  
newsletter@OttawaValleyQuiltersGuild.org

**Photographer:** Margaret Dunsmore

**Program:** Vikki Zulpo, Alison Tranter  
program@OttawaValleyQuiltersGuild.org

**Publicity/ Shop of the Month:** Janet Patch,  
Eden Thurston

**Social:** Ann Gorman, Bernice Nagle

**Quilt Show:** (vacancy)

**Volunteer Coordinators:** Peggy Schenk, Barbara Robertson, Cathlyn Kaufman

**Website Coordinator:** Katrina Roddick

**Workshops:** Shirley Bolduc, Margery Windover  
workshops@OttawaValleyQuiltersGuild.org

## THE MINUTES

from the previous month's meeting are posted on the Bulletin Board. If you have any corrections, please see Carol Kerfoot.

## PROGRAM

**TTT this month (Tips & Techniques Table) will feature Alison Tranter, showing us a great way to make pillowcases. It's easy, and the finished product has no seam showing. Bring a pen/paper to jot down a few notes so you won't forget!**

This month we will be hosting the talented Pippa Moore from Comox, British Columbia. A former member of our Guild, Pippa is now the owner of Kitambaa Designs. Her trunk show is entitled "An African Adventure". It will be a showcase of quilts made with African fabrics, and inspired by Africa. It will be full of the stories of the women of Africa, including the group of Ugandan women with whom she is currently involved teaching sewing and quilting. Don't forget to bring your friends!

Pippa will also be our Shop of the Month with African themed batiks, other fabrics and her own patterns.

See her fabulous creations at [www.pippamoore.ca](http://www.pippamoore.ca).

Our guest for **December** will be Helen Fujiki from Toronto. Helen is best known for her personal style, which she calls FujiWa, a combination of broderie perse, machine and hand appliqué, with the use of panels. Helen will be presenting: "Japan Through the Eye of a Quilter". Helen writes: "The 2008 Tokyo International Great Quilt Show, the largest quilt show in the world, kicked off my adventure in Japan which was part sightseeing and part textile tour. You will see what their quilt artists are producing, along with highlights of competition quilts for 2008. You will hear about the original 5 quilt masters who fostered the growth of quilting in Japan, and you will see the works of one of those masters, who I was lucky enough to meet. I took workshops and visited artisans, and you will see what they were all about. At the very least, you will gain some knowledge of Japan and Japanese design. Along with a display of my Asian work, there will also be a display of over 50 Manhole Cover Quilts which I have just completed. What you will see will inspire and refresh!"

Helen will also be giving a FujiWa workshop on Monday, December 7<sup>th</sup>. (Likewise on December 8<sup>th</sup> for Common Thread Guild and presenting the same lecture that evening.) Check out the fabulous gallery on her website [www.helenfujiki.com](http://www.helenfujiki.com).

### **Looking ahead:**

In **March** we host **Kathy K. Wylie**, author of "Sewflakes", a book about papercut appliqué. The title of her lecture is "Beauty is All Around". Kathy writes: "Beauty really is all around us and provides a constant source of inspiration. This lecture takes a closer look at designs that are circular or radiating in nature. My complete collection of papercut appliqué quilts is examined in detail, revealing how each motif is transformed into a snowflake, a block and a quilt." Kathy will have her book for sale and will sign any you might already have.

Check out her website, [www.kathykwylie.com](http://www.kathykwylie.com) and sign up for one or both of her workshops.

...more

## Program, cont'd ...

In **April** we are very fortunate to have **Dena Crain**, all the way from Kenya, Africa. She is doing a fabulous two-day workshop for us entitled "Ladders and Crystals". Take a look at some of her "Ladder" and "Crystal" quilts in The Gallery at [www.denacrain.com/blog](http://www.denacrain.com/blog). Here's your chance to take your quilting to the next level under Dena's expert guidance. The workshop will teach a technique, you do not have to replicate her patterns. After she leaves us, she will be teaching at the Chicago International Quilt Festival, and the week after that at Quilt Canada.

Take a look in the program section of our Guild's website for a listing of guests and activities planned for the rest of the year. I think you'll find there's a lot to get excited about!

Vikki Zulpo, Alison Trantor



## BOOKMARKS FOR QUILT CANADA

Our Guild is making bookmarks for Quilt Canada 2010 in Calgary – something useful and beautiful to put in the delegates' bags. Everyone is asked to please make at least two bookmarks. Be creative —use any technique or design. Size: 2-3 inches wide and 6-8 inches long (unless you make skinny ribbon-type bookmarks), and thin enough to put in books without causing distortion. Bookmarks will be collected at every meeting from now until the March 1 meeting. Enquiries to Barb @ 613-729-4872.

Barb Cloutier



**Flair With Fabrics**  
Ruth Liscumb  
Fabric - Yarn - Patterns - Notions  
HOURS:  
Mon. - Thurs. 9 - 5:30  
Fri. 9 - 6 Sat. 9 - 4  
3 King Street  
Chesterville ON K0C 1H0  
613-448-9032 [rliscumb@gmail.com](mailto:rliscumb@gmail.com)

## AT HOME WITH QUILTS



1. We need designer(s) for publicity posters and bookmarks. Designers need to start now to be ready for publicity. You need not commit to doing Publicity, per se, but we'd welcome your help.
2. We have lost a house in the Glebe. We need a replacement in the Glebe, Manor Park or Alta Vista areas. Two houses would be great. Can you help?
3. Membership are asked to make show items in themes of Animals, Children, Seasons, of/for/by Men and Art in the form of quilts, wall hangings, tableware, tea cozies, pillows, window and shower curtains...
4. Membership are asked to make items for the Charity Sale. As we all know, everyone wants a bargain - although last year one quilt did sell for \$150.

We meet in St. Anthony's downstairs pub at 6:30 before the meeting. Come and join us if you'd be willing to help organize the Tour for October 2010. Many have volunteered to help in the houses but there will be lots to do before that weekend.

Pat Amundrud

## LIBRARY

The Library would like to thank Elaine Quehl for her very generous donation of thirty-six books to our collection. They are a wonderful addition to our library holdings and will certainly be enjoyed by our Guild Members .

## MEMBERSHIP

Be sure to pick up your **Membership Directory** at the Membership Desk. Those not picked up will be mailed out later in the week. Remember that this Directory is provided solely for the personal use and communication of OVQG Members.

**OVQG name tags** can also be ordered at the Membership Table. The cost is \$10 to be paid at the time of ordering. To keep the costs down, the badges are ordered in batches. The next order will be placed early in November.

Carol Baker



## CHARITY QUILTING

We are changing the hours at Maki House to 1:00 to 5:00 PM. We encourage you to come to do charity work. Bring your sewing machine and make premie quilts, or quilts for May Court or else help with the hand-quilting of our queen-size quilt which will be donated to a not-for-profit organization.

Thank you all for the 125 placemats! We sent them to Meals on Wheels for their Thanksgiving frozen meals. We did such a great job making these placemats, they would like more of them for Easter.

Upcoming activities:

1. Come join Grace MacNab at Maki House on November 22<sup>nd</sup> from 10 AM to 4 PM to make Fidget Quilts for the Civic Hospital Emergency and Continuing Care Department and you will have the chance to make one, in time for Christmas, for a friend or relative with the disease. At least four finished quilts and a dozen or so alternate blocks will be on display. We will have a stock of textured fabrics and embellishments on hand, but attendees are invited to bring their own.
2. May Court Hospice is looking for quilts which will be used on their double beds. There will be assembled fabric packets at a cost of \$1.00 per package, which is refundable when the block is complete. These can be picked up at the Charity table at our December meeting, or you can make your own quilt (78" x 88") from extra fabrics you may have on hand. See me for details.
3. Thank you for all the donated fabrics. They will be put to good use in the making of quilts, placemats and Fidget Quilts.

Jane Roszell



*Offering a Full Range of Supplies  
for the Creative Quilter*

2211 St Joseph Blvd Orleans ON K1C 7C5  
613-834-3044 [www.quiltypleasures.ca](http://www.quiltypleasures.ca)

**Orleans ... It's Not as Far as You Think**

## Supply List for Fidget Quilts

*(81/2" squares, overall dimensions min. 24" x 24")*

There will be some materials available for use but I encourage you to bring your own:

1. Textured fabrics include fake fur, ridged or sculpted terry towelling, upholstery fabrics, satin, sateen, velveteen, silks, brocades, corduroys, cords, etc. Fabrics should be pre-washed.
2. Embellishments include buttons and beads with big holes (to be attached with shoe lace, heavy gros-grain ribbon, nylon cord, twill tape or equivalent; never just sewn on), lace, ruffles, gimp, rickrack, sturdy netting (e.g., garment washing bags), gold and other braid, etc. No glass beads and no attachments with sharp edges or corners can be used.
3. Quilters should also bring their usual sewing supplies, rotary cutter, mat, ruler and sewing machine if possible.

*Barb Gillespie  
Quilter*

---

**CHERRY TREE QUILTS**

---

*Longarm Machine Quilting  
&  
Custom Made Quilts*

*By appointment only  
613-823-7094  
Ottawa ON  
K2J 4L2  
[cherrytreequilts@magma.ca](mailto:cherrytreequilts@magma.ca)*

## BABY QUILTS



Another WOW!!

At the October meeting we collected a whopping 63 baby quilts donated by just 17 very generous members. A very BIG thank you to all! The nurses at the Rich Little Nursery were incredulous — and VERY pleased and thankful — at the number of gorgeous little quilts we've brought them in just a couple of months.

For simple design ideas to make the 24" square quilts, see me at the Baby Quilt Table where I will have patterns for sale at \$0.50/set (to offset the cost of photocopies).

There will also be a sign-up sheet to see if there is enough interest for a baby-quilt-a-thon at Maki house on a Wednesday afternoon or evening in January of 2010.

A gentle reminder: please indicate **OVQG** somewhere on your quilt using your preferred method of labeling.

Thank you again and see you at the next meeting.

Carole Carraro



A very big **THANK YOU** to the following ladies who came out our to our Charity Quilt Day to make quilt tops for Victoria's Quilts Canada..

"Well done" to Jann, Glenna, Betty, Evelyn, Mavis and a very special "well done" to June who was our official "press and un-sewer" gal for the day. We were able to complete 6 tops with two more to come. Not a bad day's work! A good time was had by all.

Shirley Bolduc

Pat Amundrud found this tip in the Lions Gate Quilt Guild newsletter...



When you finish making a quilt, use some of the fabrics to make a "pillow case" for the quilt to be stored in when not in use. Make a zipper closing so the quilt can't "escape". The zippered pillow case acts as a dust cover. The scraps of fabric help Identify what's inside. If the quilt should need repairs, the fabric from the dust cover can be used.

## Julee's

5502 Osgood Main St.  
Osgoode Village, ON  
613 -826-1243

www.julees.ca • julees@sympatico.ca

Mon: 9:30 am—2:30 pm

Tues-Fri: 9:30 am—5:30 pm

Sat: 10 :00 am—5:00 pm

Mark this date on your calendar:

**November 23 - 28**

**Julee's Pyjama Sale**

**Buy one item/metre at regular price  
and get a second item of same or lesser  
value at 85% off...**

**BUT**

**to get this discount you must come into the  
shop wearing P.J.'s and curlers and bring a  
non-perishable food item for the food bank.**

**It's a hoot—lots of laughs, great buys,  
good fun and many friends!**

**With the coming of Christmas this year, so  
comes the end of another chapter in the  
Osgoode Village history as I will be retiring  
and Julee's will close its doors for the last  
time. I want to take this opportunity to thank  
you all for your friendship and support.  
It has been an honour serving you.**



2679 Alta Vista Drive Ottawa ON K1V 7T5  
613-521-9839

(Alta Vista Shopping Centre—Alta Vista Dr. & Bank St.)

Monday to Thursday 10-5:30 • Saturday 10-5:00

Fridays 'til 7:00 (except Jul & Aug)

## Mystery Quilt CLUE #3

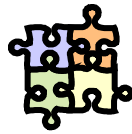

Clues for this 'Mystery Quilt' started in the September newsletter. Please register your participation by November 2009. There will be a prize drawn for those who bring the completed quilt to the May meeting! If you have questions, call me at 613-838-5347.

Alison Tranter

### **A Patchwork Puzzle**

#### **A Judy Hopkins Mystery**

(Contents Copyright 2006 Judy D. Hopkins)

Join the 2-5/8" DARK half-square triangles and the 4-3/4" LIGHT quarter-square triangles to make 68 Flying Geese units as shown.

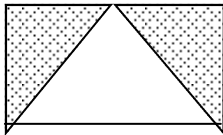

Make 68

Press the seams toward the DARK triangles. The units should measure 2-1/4" x 4" (raw edge to raw edge) when sewn.

### **STITCHING TIPS FOR "FLYING GEESE" UNITS**

1. Join left-hand triangle: Match points (A) and bottom edges; sew in direction of arrow. Press seam toward smaller triangle.

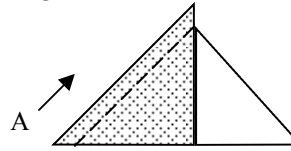

2. Join right-hand triangle. Start at arrow. Your 1/4" seam should EXACTLY intersect the 90-degree angle where the two smaller triangles meet, as in the magnified portion of the drawing. Adjust the position of the loose triangle until the seam lines up correctly. Take a few stitches, then match points (B) and finish stitching the seam. Press seam toward smaller triangle.

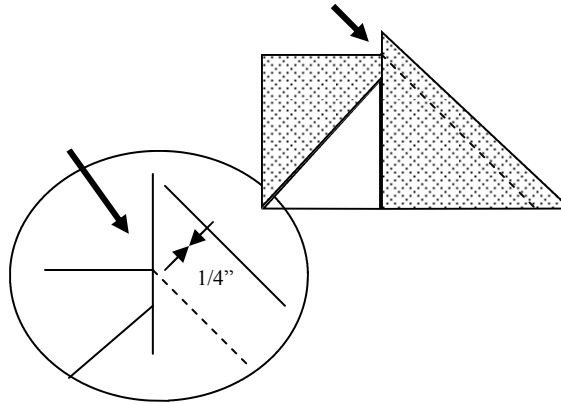

**Wendy Foster**  
fosterwen@yahoo.ca  
Tel.: 613-830-5636

### **Original Custom Machine Quilting**

*No wait times*

#### **Quality Threads**

*Sew like a dream*

#### **Threads**

Superior's Rainbow and Bottomline,  
Madeira's Supertwist, Polyneon, FS/20,  
Yenmet Metallic Threads

#### **Needles**

Schmetz Topstitch 90/14 and Double eye



## **The Quilting Quarters**

*Fabric, Classes, Notions, Kits, Patterns*

*Tin Lizzie 18 Home Longarm System*

*Authorized JANOME Dealer*

14 Industrial Dr  
Box 329, Almonte, ON  
K0A 1A0

613-256-4248  
quiltingquarters@bellnet.ca  
www.quiltingquarters.ca



**Come visit us at The Running Stitch  
“...Where we inspire you to create”**

Our immense selection of fat quarters and the latest fabric collections are second to none!

You'll enjoy visiting with our fun loving and knowledgeable staff!

Browse through our huge selection of books, patterns, notions, accessories, kits and fabrics

There's so much more we have to offer to fulfill your sewing and quilting needs that you will just have to come in and see it all for yourself!

Join our email list, call or write us at: [therunningstitch@on.aibn.com](mailto:therunningstitch@on.aibn.com)

**We're open: 10:00 am to 6:00 pm on Monday, Tuesday, Wednesday & Friday  
10:00 am to 8:00 pm on Thursday and 10:00 am to 5:00 pm on Saturday**

Inquire about a demo on the New Bernina 830 or any of the Bernina Machines in our store.



If you can't make it in we invite you to visit us on our website: [www.therunningstitch.ca](http://www.therunningstitch.ca)

**QUILTERSRACK.COM**

**16 Beckwith St.  
Smiths Falls (613) 284-1551  
[quiltersrack@bellnet.ca](mailto:quiltersrack@bellnet.ca)**

**Tues-Fri 9:30-5:00 Sat 9:30-4:00**



**We are now an authorized dealer for:**



- NEW FABRICS in every month!**  
 Long-arm quilting service  
 NEW Classes  
 NEW Books  
 NEW Patterns  
 NEW Notion

**We carry these magazines:**

- |                      |                       |
|----------------------|-----------------------|
| Country Threads      | Country Patchwork     |
| Patchwork & Quilting | Patchwork & Stitching |
| Down Under Quilts    | Quilt Sampler         |
| Quilter's World      | Creative Expressions  |
| Quilting Art         | Quilt Mania           |



**BLACK BIRD  
COUNTRY  
QUILT WORKS**

**FOR TOP QUALITY  
QUILT FABRICS AND MORE!**

Wendy Simpson  
2309 Front Road  
Normandale, ON  
519-426-0736

Thurs to Mon 9:30-5:00  
[www.blackbirdcountry.com](http://www.blackbirdcountry.com)

# WORKSHOPS

Workshop Policy is posted on the website and on the bulletin board at the meeting. Please read.

For more information please visit the Workshop Table or e-mail your question to workshops@OttawaValley-QuiltersGuild.org. Fees for non-OVQG members are given in brackets.

## Open Thread Bar Workshop

**Instructor:** Anita Zobens, Superior Thread Educator (Canada)  
**Date:** Saturday, November 14<sup>th</sup>  
**Time:** 10:00 am – 4:00 pm  
**Location:** Maki House, 19 Leeming Drive  
**Class Fee:** \$50 (\$60)  
**Kit Fee:** \$5



**Description:** Are you overwhelmed with choosing threads for your quilting projects? With so much variety available today it can be exciting and, at times, confusing. This presentation will enable you to make an informed decision. Students will learn about the different fibres and weights, how to choose the correct needle size and how to adjust the dreaded tension dial. We'll overcome our fear of metallic or specialty threads. Anita will tell us more about the 'dust bunnies' in our machine, where they come from and what to do about them. Threads will be available for purchase.

## "Fuji Wa" – Hands On

**Instructor:** Helen Fujiki  
**Date:** Monday, December 7<sup>th</sup>  
**Time:** 9:00 am – 4:00 pm  
**Location:** Woodvale/Manordale Community Centre, 68 Knoxdale Road  
**Class Fee:** \$60 (\$70)



**Description:** "Fuji Wa" is Helen's style of combining patchwork, panels, and appliqué (Broderie Perse, and conventional machine and hand appliqué) to create Asian-inspired hangings. The whole system provides you with an unlimited amount of freedom to use techniques you love to do. You get to cut loose! There is no right or wrong, if it is what you want to express. Visit Helen's website at <http://web.me.com/helenfujiki/Site/Welcome.html>

## Beginner Free-Motion Quilting

**Instructor:** Linda Palaisy  
**Date:** Saturday, January 16<sup>th</sup>, 2010  
**Time:** 9:00 am – 4:00 pm  
**Location:** Maki House, 19 Leeming Drive  
**Class Fee:** \$30.00 (\$40)

**This class is full but we have started a waiting list for a second class on Saturday, January 30th. See us at the 'Workshops' table.**

**Description:** This Free-Motion Quilting Workshop begins with setting your machine for this type of work, including how to get the best out of your particular sewing machine and how to handle the work. Reference is made to Quilt-As-You-Go techniques since smaller pieces are easier to handle and allow you to achieve good stitching more easily. First we will simply move the fabric around under the needle to get a feel for what free motion is all about, and then we move into doodling, writing your name and other exercises that we all do already with a pencil and paper. Then we move into more recognized quilting patterns such as stippling, loop-the-loop, swirls, circles, stars, pebbles, etc. All of this is worked on 12" square quilt sandwich blocks with contrasting threads. Other aspects covered include threads, tension, stitch length, etc. Detailed notes with sketches are provided and lots of samples will be shown. Your class samples can then be made into a quilt or throw, if you wish. Instructions of how to join them together will be given in the notes.

...more

### Introduction to 'Paintstiks'

**Instructor:** Mary Pal  
**Date:** Wednesday, January 20<sup>th</sup>, 2010  
**Time:** 1:00 – 4:00 pm

**OR**

**Date:** Saturday, January 23<sup>rd</sup>, 2010  
**Time:** 9:30 am – 12:30 pm  
**Location:** Dragonfly Fabrics, 2679 Alta Vista Dr. ( Alta Vista Shopping Centre)  
**Class Fee:** \$25 (\$35)

**Description:** How can you use an oil paint stick on fabric? Let's count the ways! This versatile product will change your view of textiles: now you can add glitz, colour, texture and sheen to them to make them look just the way you want, or spice up a quilt to really make it sing. Here's your chance to experience the many ways Shiva Paintstiks can be used, from stenciling, rubbing, masking, direct application and shading, to highlighting. You will have access to the instructor's collection of rubbing plates and stencils during the class, and will go home with a detailed notebook with all the instructions so you can continue to play on your own. They're easy and fun to use (and very addictive!).

### Papercut Appliqué

**Instructor:** Kathy K. Wylie  
**Date:** Saturday, February 27<sup>th</sup>, 2010  
**Time:** 9:30 am – 4:00 pm  
**Location:** Maki House, 19 Leeming Drive  
**Class Fee:** \$65 (\$75)

**Description:** As featured in Kathy's book "Sewflakes", papercut appliqué is a technique similar to making paper snowflakes. In this workshop, you will learn from the author how to design these unique snowflakes for fabric, with an emphasis on incorporating recognizable images into the design, and then look at various ways to transfer the design from paper to fabric. [www.kathykwylie.com](http://www.kathykwylie.com)

**Prerequisite:** Some appliqué experience is helpful but not essential.

### Peek-a-boo Appliqué

**Instructor:** Kathy K Wylie  
**Date:** Sunday, February 28<sup>h</sup>, 2010  
**Time:** 9:30:00 am – 4:00 pm  
**Location:** Maki House, 19 Leeming Drive  
**Class Fee:** \$65(\$75)

**Description:** What happens when you reverse appliqué over patchwork? Peek-a-boo! Use strip-piecing to create a realistic leaf or crazy-piece a delightful embellished heart. The result looks like patchwork appliqué! Use this technique to add unexpected detail to your appliqué, make exciting border designs, or transform those orphan blocks. [www.kathykwylie.com](http://www.kathykwylie.com)

**Prerequisite:** Some appliqué experience is helpful but not essential.

### "City Shadows"

**Instructor:** Fran O'Neil  
**Date:** Saturday, March 13<sup>th</sup> and 27<sup>th</sup>, 2010  
**Time:** 10:00 am – 4:00 pm  
**Location:** Maki House, 19 Leeming Drive  
**Class Fee:** \$60(\$70)

**Description:** Are you up to the challenge of using colour to highlight your quilt? Then come out and use two traditional blocks to learn how to produce a subtle change of colour value throughout the quilt. Please bring to class a sewing machine, fabrics and supplies. [www.fransquilting.com](http://www.fransquilting.com)

...more

## Ladders and Crystals

**Instructor:** Dena Crain  
**Date:** Saturday, April 10<sup>th</sup>, 2010 and Sunday, April 11<sup>th</sup>, 2010  
**Time:** 9:30 am – 4:00 pm  
**Location:** TBD  
**Class Fee:** \$150 (\$160)

**Description:** Students learn an easy and foolproof technique to produce unique and beautifully elegant designs. The method is progressive, moving from simple modifications of common blocks through various processes and resulting in wonderful unlimited and wonderful possibilities for design. Repeat units that are not square are arranged in steps to make Ladder quilts, then tessellated and reflected into jewel-like structures to make Crystal quilts; both can incorporate straight or curved seams. Piecing perfection without unnecessary seams, careful use of color/value and print, and delicate embellishment are important topics within this workshop. As students master both Ladder and Crystal quilt design structures, the traditional grid becomes thoroughly disguised, leaving others to wonder “How DID they do that?!”

<http://www.denacrain.com>

**Focus of Class: Design, construction. Level of Instruction: Intermediate/Advanced**

## “Edges”

**Instructor:** Linda Palaisy  
**Date:** Saturday, April 24<sup>th</sup>, 2010  
**Time:** 9:00 am – 4:00 pm  
**Location:** Maki House, 19 Leeming Drive  
**Class Fee:** \$30 (\$40)

**Description:** Prairie Point, Scallop, Binding by Machine, Binding with Machine Embroidery, Binding with piping, Faced Edges, Satin Stitch Edges, Couched edges, Fringed edges. These are some of the many ways to finish the edge of your quilts. Learn how to do these various techniques and why and where you might use them. All techniques taught in this workshop use just a regular zig zag sewing machine. Learn how to give your quilts that special finishing touch. Students will make hands-on samples and notes will be given for all techniques taught. Samples will be shown.

## Advanced Free-Motion Quilting

**Instructor:** Linda Palaisy  
**Date:** Saturday, May 15<sup>th</sup>, 2010  
**Time:** 9:30 am – 4:00 pm  
**Location:** Maki House, 19 Leeming Drive  
**Class Fee:** \$30(\$40)

**Description:** The more advanced free-motion Quilting Workshop presumes the student knows how to free-motion quilt but does not need to have taken the Beginner Free-Motion Quilting class. This class quickly reviews the setting of the machine just to give new students some of Linda’s hints and tricks and maybe address some problems that people keep running into while free-motion quilting. Then there will be a little warm up of whatever students wish to do on a quilt sandwich block. This gets everyone relaxed and ensures that their sewing machines are running well. It also gives the instructor a reference as to what their individual skill level is. Next, more complex quilting patterns will be worked on — feathers, clam shells, and vines, roses, houses and trees, and whatever else time and skill level allows for. If the skill level is high and the interest is there, we may tackle trapunto, corded quilting or other interesting techniques. Notes will be given for all that is taught and more. Resulting class samples can be made into a quilt or throw and instructions on how to join them together will be given in the notes.

...more

## Finishing School

**Instructor:** Linda Palaisy  
**Date:** Saturday, May 29<sup>th</sup>, 2010  
**Time:** 9:30 am – 4:00 pm  
**Location:** Maki House, 19 Leeming Drive  
**Class Fee:** \$30 (\$40)

**Description:** Finishing School is an all day "Doctor In The House". Bring your UFO's. Whether you have hit a road block and can't figure where to go next, lost confidence in what you were doing, or just want uninterrupted sewing time in a helpful friendly setting with an expert available, this is the workshop for you. This day will give you a chance to focus on one or more of your personal quilt challenges. Tap into the expertise of your classroom educator and get the momentum restarted on those "Works in Progress". What better way to get past that hurdle then with the advice of the classroom educator and then immediate hands-on action. Go home at the end of the day seeing that old UFO with new eyes.

## Orchid with Sashiko Borders (Size: 24.5"x29")

**Instructor:** Renske Helmuth  
**Date:** Saturday, June 5<sup>th</sup> and Sunday, June 6<sup>th</sup>, 2010  
**Time:** 9:30 am – 4:00 pm  
**Location:** TBD  
**Class Fee:** \$100 (\$110)

**Kit Fee:** Complete Kit \$25, Pattern Only \$5.

**Description:** Ready for a taste of the exotic? Why not learn to appliqué this elegant orchid arrangement, embellished with sashiko stitches. Renske will guide you through the different hand appliqué techniques necessary to create the pot, then fill it with twigs, leaves and orchids. You will finish the arrangement with moss to give the whole a three-dimensional feeling. Colour selection is very important in this piece, Renske will discuss choices that create a dramatic effect. Finally, you will infuse your work with true Japanese flavour by embellishing the border with sashiko. Examples of some of the many sashiko patterns will be provided, you will be taught how to stitch this design into your own work.

Visit Renske's website at <http://renskehelmuth.blogspot.com/2007/02/workshops.html>



**Level of Instruction: ALL — though some appliqué experience is a benefit.**

### **NOTE:**

**Please ensure that you have the supply list for the workshop you have signed up for. Lists are available at the Workshop Table.**

**Shirley Bolduc**



Fabrics ♦ Patterns ♦ Notions ♦ Sewing Machines ♦  
Classes ♦ Creative Ideas

**Authorized Pfaff and Singer Sewing Machine  
Store Hours Mon-Fri 10-5 Sat 9:30-4**

104 Elgin Street West, Arnprior ON  
Phone (613) 623-0500 Fax (613) 623-0434  
[www.sewinspired.ca](http://www.sewinspired.ca) E-mail: [info@sewinspired.ca](mailto:info@sewinspired.ca)

## BLOCK-OF-THE-MONTH

Thank you to the 29 members who contributed 68 blocks in October!  
Congratulations to **Shirley Buldoc and Dianne Milks** who each took home 34 Fall Stepping Stones blocks.

### For December Meeting...

## “Glamorous Trees”

This month's block ventures into appliqué and begs for embellishment. These trees can be simply elegant or bright and flashy. Have fun!

**Fabric Requirements:** You will require four fabrics. The background is a white-on-white, tree is green, trunk is brown and the star is gold. Use small or large prints, your choice.

### Cutting:

***Background Fabric:*** *white on white:* one 9" x 11" rectangle (This will be trimmed to the finished size of the block 8.5" by 10.5" upon completion.).

*Note:* cutting instructions below are for machine appliqué on fused pieces, if you prefer other methods of appliqué, please modify instructions to suit your preferred method.

***Tree Trunk :*** *brown print:* one 1" x 1.5" rectangle

***Tree:*** *green print:* one 5.5" x 8" rectangle

***Star:*** *gold print:* one 2" x 2" square

### Assembly Instructions:

1. Take the green rectangle and fold in half along long side. Draw a straight line between the center of the top edge and the side of the bottom edge. Cut along the line to form a triangular tree.
2. Use star below to cut out star or use your own drawing with size of about 1.5" across diameter.
3. Fuse tree, trunk and star to white background with the star centered in top corner, leaving more than 0.75" from the edges to the star for the seam allowance (top right corner if you were born Jan-Jun, top left corner if you were born July-Dec). Machine appliqué the fused pieces to the background fabric. Trim the block to 8.5" by 10.5", ensuring there is at least a 0.5" seam allowance from the appliquéd pieces.
4. Decorate with button, bells, beads, bows, ribbons or embroidery.
5. Finished block is 8.5" x 10.5".

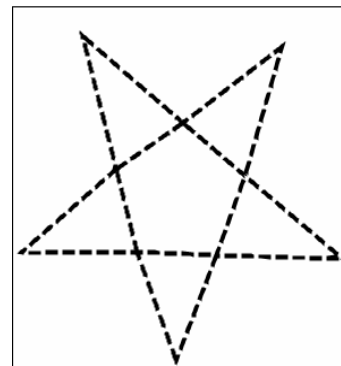
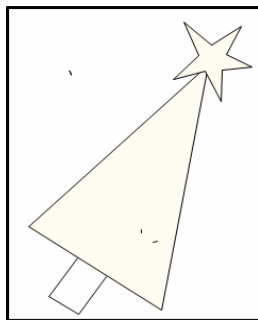
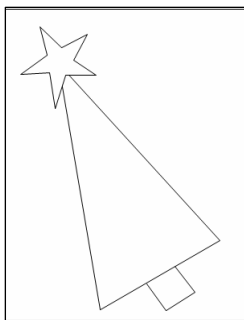

If you have any questions regarding the blocks, you can reach us by email or by phone: Heather Jarmyn (613) 823-8840, [nepeanquilter@gmail.com](mailto:nepeanquilter@gmail.com), or Robin (613) 680-2924, [Tilsworth.rude@gmail.com](mailto:Tilsworth.rude@gmail.com).

## New Zealand Visitors to OVQG have Great Day

You may recall that last spring, program co-coordinator Vikki Zulpo invited interested Members to a pot luck dinner with visitors from New Zealand. With lots of e-mails back and forth to New Zealand and to the interested participants from OVQG and the Embroidery Guild, plans were developed and the day finally arrived.

On Thanksgiving Monday the visitors arrived in Ottawa and early the next morning the 12 intrepid travellers (embroiderers and quilters) from both the North and South Islands of New Zealand boarded a bus at the Lord Elgin Hotel, joined by the Deputy High Commissioner for New Zealand (a quilter!) and three members of our guild. The New Zealanders were on a cross country tour of Canada and stayed an extra day in the Ottawa area for a Shop Hop and a pot luck dinner. While the weather was grey and dismal, the atmosphere decidedly was not.

A full day of store-hopping started at Yarn Forward where a number of members of All Dolled Up were available to talk to the girls. There was a display by “Books for You” and Linda Palaisy especially prepared for the visitors. Then it was on to Dragonfly Fabrics, The Mississippi Textile Museum and a lovely lunch at The Robin’s Nest in Almonte. The rain held off enough that the gals were able to walk a bit in Almonte — by the falls behind the museum and in town. After lunch we visited Textile Traditions and Quilting Quarters, also in Almonte, and then made a quick stop in Appleton for photos at the falls. We finished up at The Running Stitch.



To all the store owners and managers and their staff, thank you so much for all your kindnesses to our guests.....tea/coffee/treats/gifts and lots of smiles really left the “Kiwis” quite impressed with Valley hospitality! You all went above and beyond, and the OVQG thanks you so very much!

We finished the day with a pot luck dinner at Bells Corners United Church, joined by 16 from our guild, some from the Embroidery Guild and two husbands (to keep the 2 men on the trip company!) The variety of appetizers, main dishes and desserts was awesome, the company delightful, and the show-and-tell of each group’s work fascinating. We all had a wonderful time and the guests went home replete in body and soul! The OVQG is truly a great place to meet and make friends.



**Frances O'Neill**  
Quilter

**Fran's Quilting Services**  
Workshops, Commissions, Private Instructions, Patterns

**BY APPOINTMENT ONLY**

60 Sparrow Way  
Ottawa, Ontario  
CANADA K1V 9H5

Tel: (613) 733-7865  
E-mail: [franquilts@rogers.com](mailto:franquilts@rogers.com)  
Website: [www.fransquilting.ca](http://www.fransquilting.ca)

Did you know there is a new CANADIAN quilting magazine? It's called “Quilter’s Connection”. Their premiere issue features an article and project by our guest speaker, Pippa Moore, as well as an article by OVQG Member, Michele Foster. Look for it at your local quilt shop or visit their website: [www.quiltersconnection.ca](http://www.quiltersconnection.ca)





## The Quilting Bee Quilt Shop

HandiQuilter, Janome and Baby Lock Dealer  
155 Highway 20 West  
Fonthill, Ontario L0S 1E0  
TEL: 905-892-7926  
[www.thequiltbee.com](http://www.thequiltbee.com)

The Quilting Bee Quilting Shop is the largest quilt shop in the Niagara Region located in the beautiful Log Cabin in Fonthill. We have a huge selection of high quality quilting cottons with new fabrics arriving regularly. We offer classes from beginner to advanced including Block of the Month Programs. Our HandiQuilter rental program has been a huge success. You take a beginner class and then you can come into the store and quilt your own quilt using one of our HQ Sixteen machines.



The Quilting Bee is an Award Winning HandiQuilter Dealer ... Specializing in the HQ 16 ... the Number One Home Quilting System in the World! We don't just sell these great machines, we use them everyday!

The HQ Sixteen: Easy-to-use,  
Simple to Maintain, Your Best  
Choice for Frame Quilting



The HQ Fusion: 24" of  
Smooth Long-arm Machine  
Quilting!



There are many options and price ranges to choose from. Call today for more information or come in for a free demonstration!

## COMING EVENTS

### November

**14-15** “Ladies of the Lake” 27th Annual Quilt Show sponsored by the Champlain Valley Quilters’ Guild, at Shelburne Farms, Shelburne, Vermont  
Sat 10-5, Sun 10-4 Admission: \$6  
Lunch available on site  
INFO: [www.cvqgvt.org](http://www.cvqgvt.org)

**14-15** Ottawa Artisans Guild “Christmas Craft Show”  
Lester B. Pearson High School, 2072 Jasmine Crescent  
Juried Artisans  
Sat and Sun 10-4 FREE ADMISSION  
Door prizes for donations to the Gloucester Emergency Food Cupboard  
INFO: [www.ottawaartisanguild.ca](http://www.ottawaartisanguild.ca)

## CALL FOR ENTRY

The 2010 Grand National Invitational Quilt Exhibition  
“Off the Wall”

Homer Watson House and Gallery  
1754 Old Mill Road, Kitchener, O N2P 1H7

Deadline for digital entry submissions: March 1, 2010  
Show runs from May 8—June 12, 2010

For entry forms and more information visit  
[www.grandnationalquiltshow.ca](http://www.grandnationalquiltshow.ca)

**YOU** Quilt  
*On my Tin Lizzie 18 Long-arm*



- 18” throat
- Stitch regulator
- Auto needle positioner
- Extra large bobbin
- Built-in bobbin winder
- Template board
- Pantographs and laser
- Frame fits crib to king-size
- Machine training FREE\*
- Practice session – 60 minutes FREE\*
- Set-up assistance
- Quilt-by-the-hour fee

\* with a minimum 2 hour quilting time

## FOR SALE

### **AMERICAN PROFESSIONAL LONG ARM QUILTING MACHINE (ULTIMATE I)**

Machine has many extras — a 14-foot table, laser light, manual controls on both sides of the machine, thread cutter, single stitch, motorized fabric advance, overhead lighting, Hartley fence grid maker and circle maker.

This machine is in great condition and would be excellent for freehand work for either a beginner or an expert.

Priced to sell at \$4500.00 Canadian  
Call Mary Lajoie at 613-253-1558

## NEWSLETTER SUBMISSIONS

All submissions must be received by midnight on the 18th of each month. E-mail submissions are preferred. Space permitting, Guild members may submit non-commercial, quilting-related advertisements or notices at no charge—maximum 2 per year. Commercial Advertising Rates: Full page—\$50.00; 1/2 page—\$25.00; 1/4 page or Business Card Plus— \$12.50; Business Card— \$6.25

Contact: Linda Doyle, Newsletter Editor; *e-mail*, [lindas-sewing-room@rogers.com](mailto:lindas-sewing-room@rogers.com); *telephone*, 613-521-9839 (days) or 613-733-4452 (evgs); *mail*, 2286 Prospect Avenue, Ottawa, ON K1H 7G4.